



95L Series Low Profile (500N)



ALCOA ALCOFASTENING SYSTEMS

Max. tensile strength 500 N
Handle conceals all interior parts and strike
Self-compensating spring-steel drawhook
Low profile

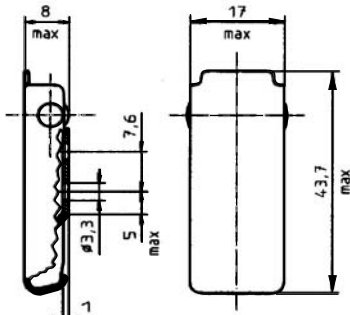
Tension Latches 1

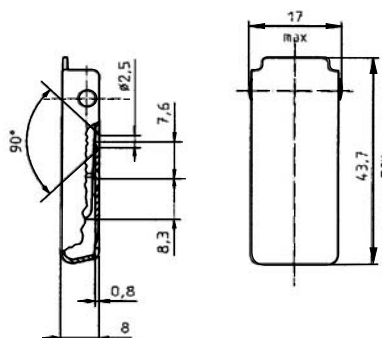
Product	Dimensions	Material / Finish	Part No.
Self-compensating spring-steel drawhook 		Stainless steel / passivated	95L07-1-1BC
Self-compensating spring elements 		Steel / chrome-plated Interior parts: Steel / zinc-plated, clear chromate	V95L15-1BD

Strike

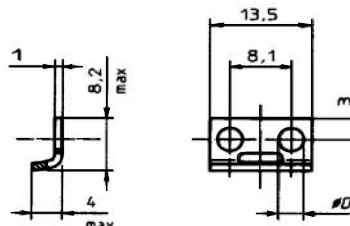
Product	Dimensions	Material / Finish	D	Part No.
		Stainless steel / passivated	Ø 3,3	95H07-1-1BC

Preferred sizes in bold type; other lengths upon request

T: + 44 (0)1803 868677 • F: + 44 (0)1803 868678

E: sales@specialty-fasteners.co.uk

W: www.specialty-fasteners.co.uk

**SPECIALTY
FASTENERS &
COMPONENTS LTD** 

Dimensions

Spring-steel drawhook tension latch / strike

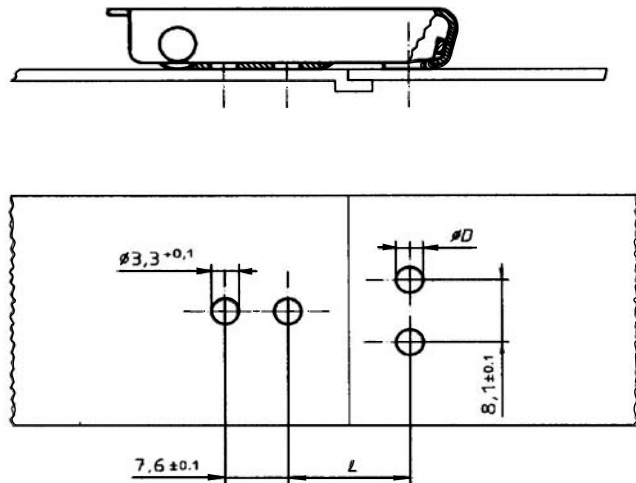
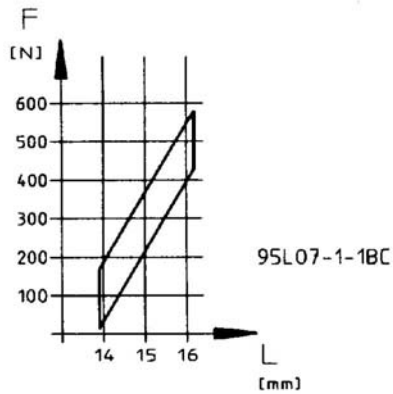

Select diameter D in accordance with the strike style

Spring elements drawhook tension latch / strike

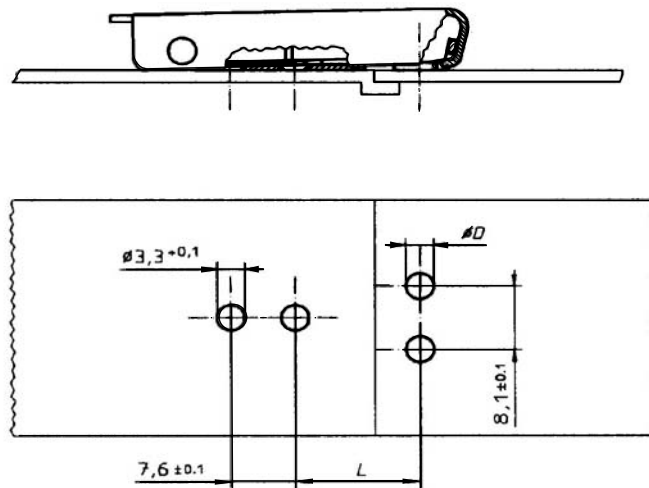
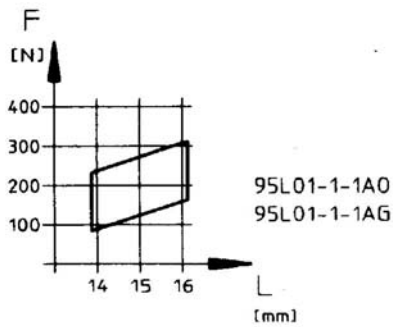

Select diameter D in accordance with the strike style